

FLUX DRIVE MANUALLY ADJUSTABLE SHEAVE DRIVE (MAS)

Adjustable Speed Control & Soft-Start for Belt-Driven Applications

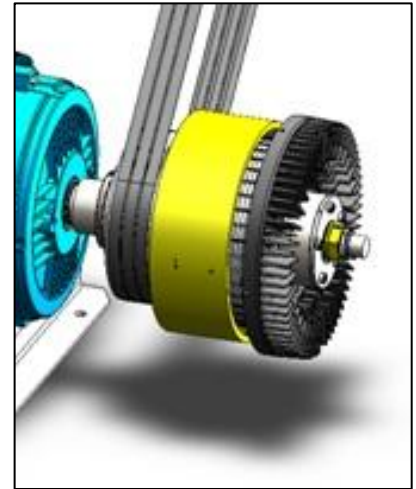

Maintenance managers know that belt-driven applications can be expensive to operate and maintain. Repeated start-up of high-inertia loads not only damages belts and sheaves, but results in high locked rotor current and costly utility demand (kW) charges. In addition, most motor driven belt driven applications are oversized. Large motors are specified to provide the necessary starting torque, but run relatively unloaded – often well outside their highest efficiency range.

Changing speed on belt driven loads can also be difficult. The options are: 1) time-consuming sheave changes or 2) installation of costly Variable Frequency Drives. VFDs and electronic soft-starters can be complex and create reliability issues. Both have drawbacks, especially when many belt driven loads only need periodic speed adjustment (i.e., seasonal changes) and operate within a relatively narrow range (80-100% of full speed).

Until now, there has been no simple, reliable, and affordable way to provide both soft-start and trim speed control on belt-driven systems. The Flux Drive MAS solves that problem!

Soft-start and Utility Demand Charges

Motor driven applications typically require maximum power (kW) at start-up – up to 7 times normal running power. Utilities will often penalize customers for this high kW “demand”.

With the Flux Drive MAS, the motor and load are disconnected at start-up, resulting in significantly reduced locked rotor current and drastically reduced initial kW demand.

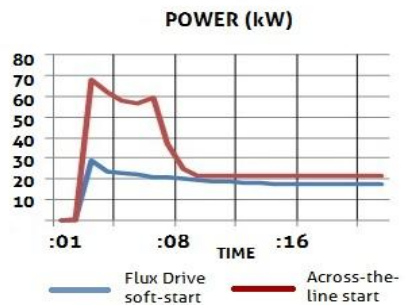

Benefits:

- Truly a ‘Green’ technology
- Provides soft-start AND **energy savings**
- Reduces expenses related to belt/sheave wear/maintenance due to hard starting
- Protects equipment from load seizures
- No external power source required
- Simple, 30-minute installation without permits or electrical staff
- Impervious to power spikes, sags, or dirty power effects
- Improves lifespan of connected equipment by reducing torsional shock / loading
- Just a 5-minute annual maintenance requirement to grease bearings
- Belt driven torque transfer that **Never Wears Out!**

How it Works:

As with all Flux Drive products, rare-earth permanent magnets and our patented induction rotor technology are at the heart of this innovative device. The Flux Drive MAS slides onto the motor shaft and is secured with a common coupling. Belts are connected to the magnet cylinder via an integral sheave. Heavy-duty tapered roller bearings provide rotational independence between the two sides, which are always separated by a 0.070" air gap.

When motionless, magnetic attraction between the rotor and cylinder is relatively low. As relative motion increases, a directional current is developed within the induction rotor itself. This current creates a magnetic coupling effect that builds rapidly across the air gap until the drive is able to rotate the load. The time between full "slip" at start-up and full load speed is the soft-start period – typically 5-10 seconds. At full engagement, the device operates at 98.5% efficiency.

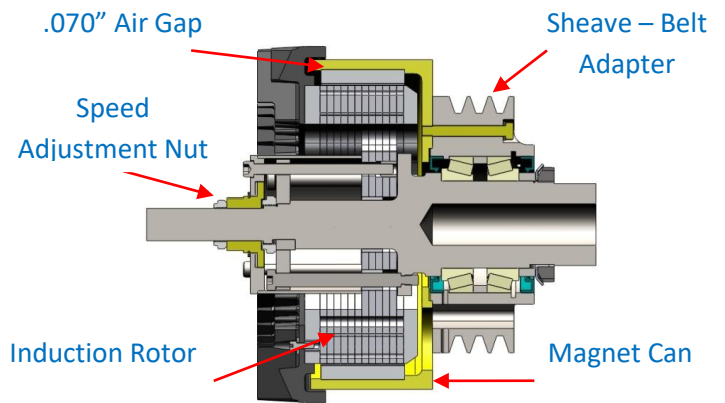

MAS OPERATING SPECIFICATIONS

Model / Size	Max. Operating Torque		Rating @ 1800 RPM (98% Efficiency)	Rating @ 3600 RPM (98.5% Efficiency)
	Lb-ft	Nm	HP	HP
10-90- MAS	90	122	30	60
10-120- MAS	120	163	40	80
10-150- MAS	150	203	50	100
12-180- MAS	180	244	60	120
12-225- MAS	225	305	75	150
14-300- MAS	300	407	100	200
16-375- MAS	375	508	125	250
16-450- MAS	450	610	150	300
18-600- MAS	600	813	200	400
20-750- MAS	750	1016	250	500
20-900- MAS	900	1220	300	600

About Flux Drive

Flux Drive Inc. designs and manufactures permanent magnetic adjustable speed drives and couplings that increase the life and performance of rotating equipment. The company's patented technology greatly lowers energy consumption and extends the life of motor driven systems by allowing motors to run at constant speed while the Flux Drive device provides soft starting and/or adjustable speed. For more information about Flux Drive, please visit www.fluxdrive.com.



6915 South 234 Street Kent, Washington 98032
 Phone: (425) 251-8777 Web: www.tritecmfg.com
 Web: www.fluxdrive.com

